

OWNER'S MANUAL



Warning

- ! Do not slide, climb, or play on pole.
- ! Keep organic material away from pole base. Grass, litter, etc. could cause corrosion and /or deterioration.
- ! Check pole system twice a year for signs of corrosion (rust, pitting, and chipping). Remove rust and/or loose paint completely and repaint with exterior enamel paint. If rust has penetrated through the steel anywhere, replace pole immediately.
- ! Check unit before each use for loose hardware, excessive wear, and signs of corrosion and repair before using.
- ! During play, use extreme caution to keep players face away from the backboard, rim, and net.
- ! Wear a mouth guard when playing to avoid dental injuries.
- ! When adjusting height, keep hands and fingers away from moving parts.
- ! During play, do not wear jewelry (rings, watches, necklaces, etc.). Objects may entangle in net.



Pro Dunk® Bronze or Silver Basketball System

MODEL NUMBER
PD-S-A | PD-B-G | PD-B-A

WELCOME TO THE FAMILY OF PRO DUNK® OWNERS

Thank you for purchasing our basketball system. We try hard to ensure that our products are of high quality and free of manufacturing defects and of missing parts. However, if you have any problems with your basketball pole, such as a manufacturing defect or a missing part please contact us at the following:

Toll Free: 1.800.294.4667
Web: www.hoopsincorporated.com
FAX: (281) 357-4822

Hoops Incorporated
22047 Lutheran Church Rd.
Tomball, TX 77377

Please provide model number, serial number, and/or part number of the product and/or part when you call, write or email. These numbers can be found on the product, packaging, or in this owner's manual.

Read this manual all the way through before starting to put up your pole. Then read each step completely before beginning that step.

Bill of Materials

Ref.	Qty.	Description
A	1	Vertical Post
B	1	Main Extension Arm
C	2	Parallel Linkages
D	1	H-Frame Backboard Mount
E	1	Spring-Assist Cartridge
F	1	Crank Adjustment Cylinder
G	2	14mm X 12cm Hex Bolts
H	2	14mm Lock Nuts
I	4	16mm X 31cm Hex Bolts
J	2	16mm X 27cm Hex Bolts
K	6	16mm Lock Nuts
L	4	16mm Anchor J-Bolts
M	8	16mm J-Bolt Hex Nuts
N	1	Anchor Footing Template
O	4	Anchor Footing Rebars
P	8	8mm X 2.5cm Machine Screws
Q	8	8mm Flatwashers
R	8	8mm Lockwashers
S	8	8mm Hex Nuts
T	1	Rim Height Sticker
U	1	Rim Height Indicator
V	4	Plastic and Steel Spacers
W	4	16mm Anchor J-bolt Washers
X	1	Black Safety Rod And Pin
Y	4	16mm J-Bolt Gusseted Hex Nuts With Built-In Washer

Installation Instructions

In order to have the safest, fun and longest use of your Pro Dunk® system, please note and heed the following:

1. Prior to goal assembly, call utility services for location of underground utility lines before you dig.
2. NOTE: Immediately unpack all components and cross check against bill of materials. Report any shortages to Hoops Inc. customer service at 1.800.294.4667.
3. Assembly is a two part process.

PART 1

- Day 1.** Complete Anchor System Installation Instructions. (Below)
- Day 2.** Allow concrete to cure.
- Day 3** Allow concrete to cure.
- Day 4.** Allow concrete to cure.

PART 2

- Day 5.** Complete Pro Dunk® assembly instructions.

4. For safety measures, have at least 3 capable persons to assist you in assembly of your Pro Dunk® Goal.

ANCHOR SYSTEM INSTALLATION INSTRUCTIONS (Day 1)

WARNING

Before digging the hole for this pole, check for buried power, gas, water, and telecommunication lines! Failure to do so could result in serious or fatal injury! Contact your local utility company if unsure.

1. Choose the proper location to dig for the concrete footing. Use the distance chart in **figure C** to help you make your decision. When choosing the exact position to dig, make sure to maximize the amount of playing surface while minimizing possible driveway obstruction.

Rim Height	Distance from the face of the backboard to the front of the Vertical Post (A)
6'	53"
8'	54"
10'	36"

2. Dig hole 36" deep and 20" square. Be sure to bell out the bottom 12" of the hole to give added stability to the footing.

NOTE: *If you live in an area where the frost line is below 36" it is advisable to dig to normal frost line. Do not cheat on the hole size, it is imperative that the hole be a minimum of 36" deep and 20" square!*

3. Assemble the anchor kit as shown in **figure B**. First thread a 16mm J-Bolt Hex Nut (M) 2 ½" of the way on to each 16mm Anchor J-Bolt (L). Place the threaded end of each 16mm Anchor J-Bolt (L) through the 4 holes located in the Anchor Footing Template (N). Then thread a second 16mm J-Bolt Hex Nut (M) on to each 16mm Anchor J-Bolt (L) until tight against the Anchor Footing Template (N), making sure to keep the 16mm Anchor J-Bolt (L) hooks pointing in toward the center of the Anchor Footing Template (N).
4. For this step you will need: level, broomstick and tape measure. The 36" x 20" anchor footing will require a little over a 1/3 yard of 3000 psi concrete (18-20 60 pound sacks of premix concrete). More will be needed if you dig a larger hole.

NOTE: *Make certain that you have enough concrete to finish the job. Allowing a portion to dry while you purchase more concrete will weaken the footing.*

5. Mix the concrete according to the instructions on the bag. Fill the hole full to ground level with as little time between batches as possible.

NOTE: *It is better to mix it slightly wet than too dry.*

6. Insert the broomstick in 3 or 4 different places and vibrate up and down to settle the concrete. Submerge the four Anchor Footing Rebar (O) pieces into the center of the hole spaced evenly. Next set the anchor system into the wet concrete, vibrate it as it goes in to make sure the concrete fills in around the 16mm Anchor J-Bolts (L) hooks. Make sure the Anchor Footing Template (N) is pressed firmly against the top of the wet concrete. Use the level to ensure that it is level in all directions. Additionally, the center line of the 16mm Anchor J-Bolts (L) must be parallel with the edge of the playing surface (See **figure C**).

NOTE: *The four 16mm J-Bolt Hex Nuts (M) on the bottom of the Anchor Footing Template (N) will be sacrificed into the concrete.*

STOP HERE!

Allow footing to cure for 3-7 days before proceeding.

PRO DUNK® ASSEMBLY INSTRUCTIONS

(~Day 5)

7. Loosen the top four 16mm J-Bolt Hex Nuts (M) from the 16mm Anchor J-Bolts (L). Leave Anchor Footing Template (N) in place.
8. Put the 16mm Anchor J-bolt Washers (W) on each Anchor J-Bolt (L).
9. Place the Vertical Post (A) down over the footing making sure not to damage the 16mm Anchor J-Bolts (K) threads. Using the 16mm J-Bolt Gusseted Hex Nuts With Built-In Washer (Y), bolt down Vertical Post (A) finger tight with two metal ears to the rear.
10. Level the Vertical Post (A) by adjusting the 16mm J-Bolt Hex Nuts (M) located underneath the flanged base plate of the Vertical Post (A). Then tighten top 16mm J-Bolt Gusseted Hex Nuts With Built-In Washer (Y) against the top side of the flanged base plate of the Vertical Post (A).
11. Slide the Main Extension Arm (B) over the top of the Vertical Post (A) and attach to the lower pivot tube with a 16mm X 31cm Hex Bolt (I) and a 16mm Lock Nut (K).
12. Slide the hole located in the Rim Height Indicator (U) over one of the second set of welded tubes on the Main Extension Arm (B). Attach the Spring-Assist Cartridge (E) to the second set of attachment holes on both the Main Extension Arm (B) and Vertical Post (A) welded tabs utilizing a 16mm X 31cm Hex Bolt (I) and a 14mm X 12cm Hex Bolt (G) as shown in **figure A.1**. Tighten each with a 14mm Lock Nut (H). The Rim Height Indicator (U) should now hang freely along side the Spring-Assist Cartridge (E).
13. Next attach the Crank Adjustment Cylinder (F) using a 16mm X 31cm Hex Bolt (I) at the top and a 14mm X 12cm Hex Bolt (G) at the bottom. Tighten each with a 16mm Lock Nut (K) and 14mm Lock Nut (H). Next, remove and discard the blue plastic spreader tube from Spring-Assist Cartridge (E).
14. Attach Parallel Linkages (C) to Vertical Post (A) with a 16mm X 27cm Hex Bolt (J) and a 16mm Lock Nut (K).

NOTE: *It does not matter which end of the parallel link you attach to the vertical post.*

CAUTION: *Injury may occur if linkages are allowed to fall off main arm during assembly.*

15. [THIS STEP HAS ALREADY BEEN DONE DURING REASSEMBLY]
Next, lay the H-Frame Backboard Mount (D) down into backboard aligning the four top and bottom holes in the H-Frame Backboard Mount (D) with the four holes in the top and bottom of the backboard (see **figure D**). Check to make sure the rim hole pattern in the H-Frame Backboard Mount (D) lines up with the rim hole pattern in the backboard, adjust as needed.

When you are satisfied with alignment, attach backboard to H-Frame Backboard Mount (D) at all points along the top and bottom of the board using the 8mm X 2.5cm Machine Screws (P), 8mm Flatwashers (Q), 8mm Lockwashers (R) and 8mm Hex Nuts (S) as shown in **figure D**. Tighten all 8mm hardware.

16. Mount the H-Frame Backboard Mount (D) and Backboard assembly lower pivot tube first to the Main Extension Arm (B) using one 16mm X 31cm Hex Bolt (I) and one 16mm Lock Nut (K). Next, attach the upper H-Frame Backboard Mount (D) pivot tube to the Parallel Linkages (C) using one 16mm X 27cm Hex Bolt (J) and one 16mm Lock Nut (K).
17. Check face of backboard to see if it is level forward and back. If it is not level, correct it by adjusting the 16mm J-Bolt Hex Nuts (M) located underneath the Vertical Post (A) flanged base plate.
18. Prior to installing the rim, locate four Plastic and Steel Spacers (V). Insert them into four rim holes in the backboard. This is very important to prevent backboard breakage.

CAUTION: *Do not proceed with rim installation without these spacers!*

19. Mount the rim to the H-Frame Backboard Mount (D) and Backboard assembly using the hardware supplied in the rim box.

NOTE: *Use a level to make sure rim is level side to side before tightening nuts*

20. After everything is square, make sure all nuts on the system have been tightened.

NOTE: *Do not over tighten. If unit is excessively difficult to crank up and down the 16mm Lock Nut (K) that secures the Main Extension Arm (B) and Vertical Post (A) is probably too tight.*

21. To apply the Rim Height Sticker (T), first use a tape measure to crank rim up to exactly 10' from the playing surface. Use a pencil to make a mark on the Spring-Assist Cartridge (E) where the bottom of the Rim Height Indicator (U) stops. Then, peel and apply Rim Height Sticker (T) to outside of Spring-Assist Cartridge (E) lining up the pencil mark with the 10' mark on the Rim Height Sticker (T). See **figure A** for a diagram of a completed height indicator assembly.

NOTE: *It is advisable to wait up to two weeks to allow the anchor footing to fully cure before aggressive play.*

22. If you'd like to restrict height adjustment from 10' to 7' you can optionally insert the Black Safety Rod And Pin (X) into the tube on the back of the Vertical Post (A).

NOTE: *It is advisable to do so to avoid injury*

Installation Figures

Figure A

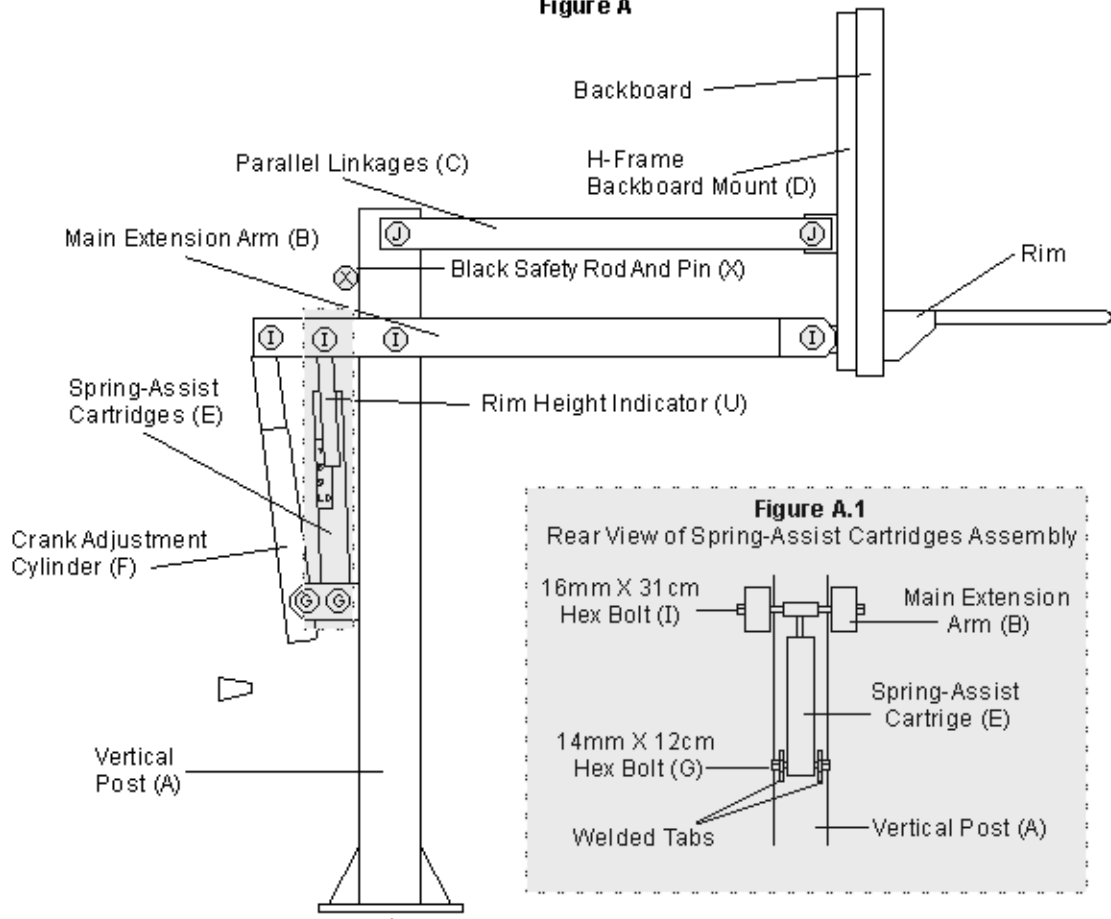

Figure A.2

Vertical Post (A) Mounted To Concrete Pier

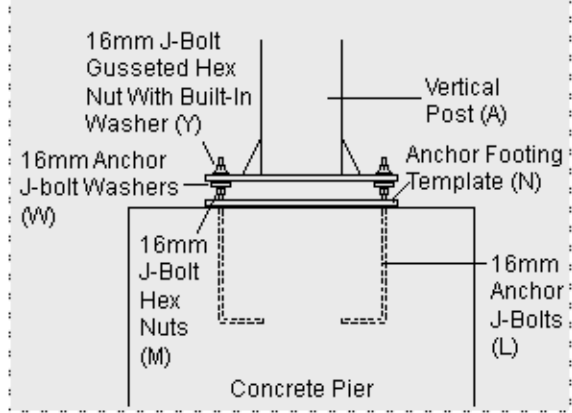

Figure B

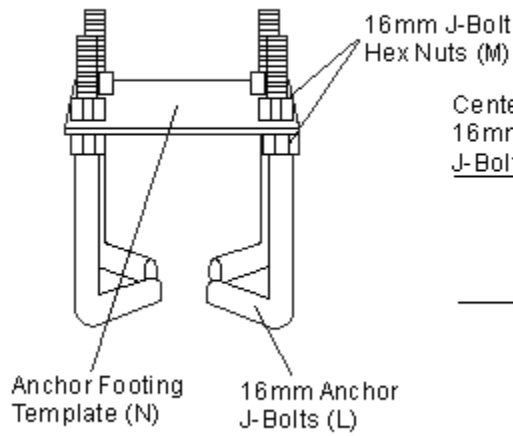

Figure C

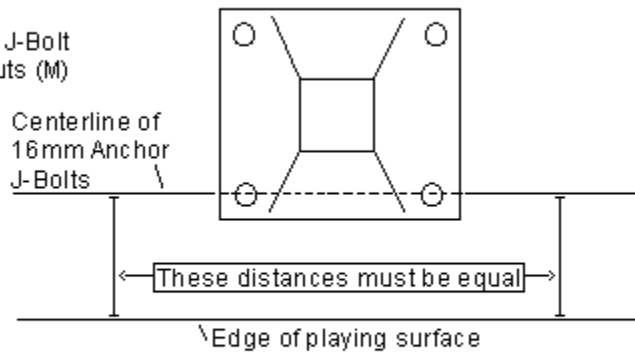
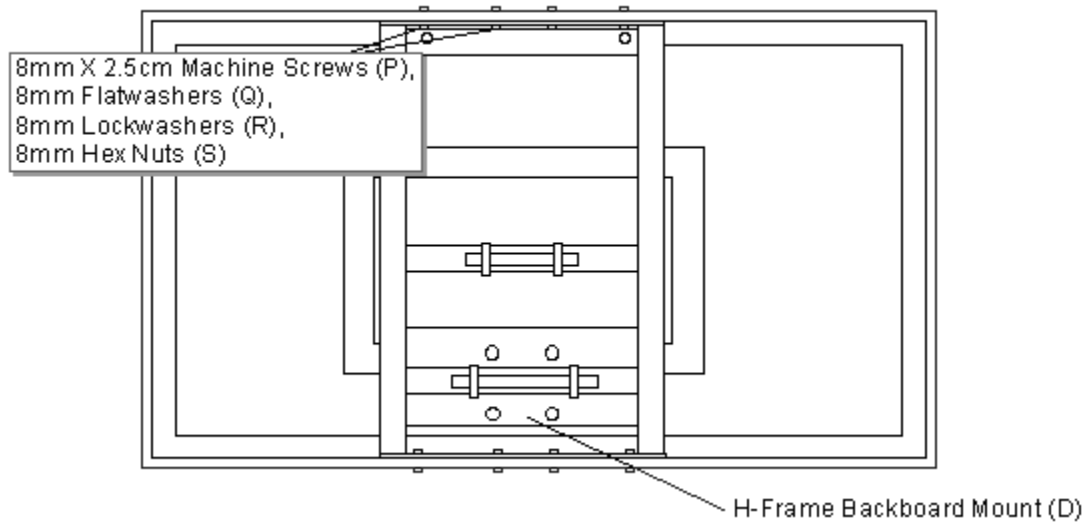

Figure D



Pro Dunk® Care Information

BACKBOARD

Items needed to clean backboard:

- 100% cotton soft cloth, (only)
- Mild dish washing liquid for soap
- Luke warm water

Cleaning Directions

Rinse backboard with lukewarm water. Wash gently with a 100% Cotton soft cloth, lukewarm water and mild soap. Do not scrub. Rinse backboard with lukewarm water again. Dry with 100% cotton soft cloth. To minimize scratches and minor abrasions to your backboard

Rim

- The goal should not be cranked under 5' or over 10'. Adjustments of the goal should be done under adult supervision.
- When attempting slam dunk activity you should always wear a mouth guard to avoid dental injury.

Hoops Inc. LIMITED WARRANTY

Manufacturer warrants to the original retail purchaser, these products to be free from defects in material and workmanship which impair the use of the product for a period often (10) years for the backboards, poles, and pole structures, two (2) years for the rim and one (1) year for adjusting cranks. Should these products become defective due to material or workmanship within the warranty period, contact our Customer Service Department for repair or replacement at our option. This warranty is not transferable and does not cover scratching or scuffing of the products which may result from normal usage, or damage caused by shipping, improper handling, installation (if not installed by our company. Hoops, Inc.), or use of this product. Nor does this warranty cover rusting or fading due to weather conditions, climate conditions, or exposure to corrosives such as salts, pesticides, etc. This warranty is also void if product is in any way abused, damaged, or modified from its original state, or if used for other designed use. Repair or replacement as provided under this warranty is the exclusive remedy of the consumer. The manufacturer shall not be liable for indirect, special, or consequential damages arising out of or in connection with the use or performance of the products or other damages with respect to any economical loss, loss of property, loss of enjoyment of use, costs of removal, installation or other consequential damages for breach of any expressed or implied warranty on these products. Except to the extent prohibited by applicable law, any implied warranty of merchantability of fitness for particular purpose on this product is limited in duration of this warranty.

© Hoops, Inc., All Rights Reserved



Toll Free: 1.800.294.4667
Web: www.hoopsincorporated.com
FAX: (281) 357-4822

Hoops Incorporated
22047 Lutheran Church Rd.
Tomball, TX 77377